



Ph: 206 403 1989
Fx: 206 282 4888
E: info@hvacep.com
W: www.hvacep.com
A: 3837 13th Ave. W Ste 104
Seattle, WA 98199

AirTest Technologies, Inc



**MODEL TR-2000
OPERATION MANUAL**



AIR QUALITY SENSOR

Installation & Calibration

INSTALLATION:

1. Locate a flat surface to mount the enclosure. The power entry is at the bottom of the enclosure. A PVC-to-thread adapter has been provided so that PVC or EMT conduit can be used.
2. Remove the cover of the enclosure by removing the 2 screws in the faceplate. Be careful here since the circuit board and sensor are connected to the cover. Set the cover/electronics safely aside while connecting the conduit and pulling in the wiring.
3. Connect the electrical fittings to the enclosure and bring in the electrical wires.
NOTE: BE SURE WIRING IS DONE ACCORDING TO THE LOCAL ELECTRICAL CODE REQUIREMENTS.

Connect the wires to the terminal block as shown on the wiring drawing. NOTE POLARITY. (See Wiring drawing). Use 18 gauge minimum wire. It is recommended that shielded wire be used if it is not being run in metal conduit.

4.

CALIBRATION AND CONTROLLER SETUP:

The AirTest TR-2000 CO (Carbon Monoxide) gas detection sensor is calibrated at the factory to a 4 to 20 milliamp output in proportion to a CO concentration range of 0 to 200 ppm. No further calibration should be required upon initial installation. Since the output of the sensor is linear, a simple formula (see below) can be used to calculate the output signal level for a given gas concentration. These calculated signal levels can be used to set a controllers ventilation or alarm trip points.

The sensor should be recalibrated if, during a verification test, the output reading is off by more than +/- 5% of full scale or, if the sensor has been in service for approximately 1 year after last calibration. Follow the steps below to recalibrate the sensor.

1. Connect the TR-2000 to a controller, one wire (16 AWG max) to + and the other to the 4-20 mA loop return (-). The connection polarity of the TR2000 is marked on the circuit board. Power-up the unit.
2. Using a DVM (Digital Volt Meter), monitor the voltage at test points (mA -) and (mA+) and adjust the ZERO trimpot so the DVM reads 40 mV (0.040 volts or 4mA)
NOTE: Calibration area must be free of gas or Zero Gas must be applied).
3. While still monitoring the test points, apply calibration gas to the sensor using the cap provided. (Flow rate 0.2 MIN TO 1.0 LPM). **NOTE:** Unlike solid state sensor elements, the TR-2000's electrochemical sensor does NOT require moisture to be added to the calibration gas stream. Wait until the reading stabilizes.
4. After the test point voltage has stabilized (approximately 1 minute) adjust the SPAN trimpot so the voltage at the test points reads the desired output (0.01 volts = 1mA) for the calibration gas concentration. See examples and formulas below.

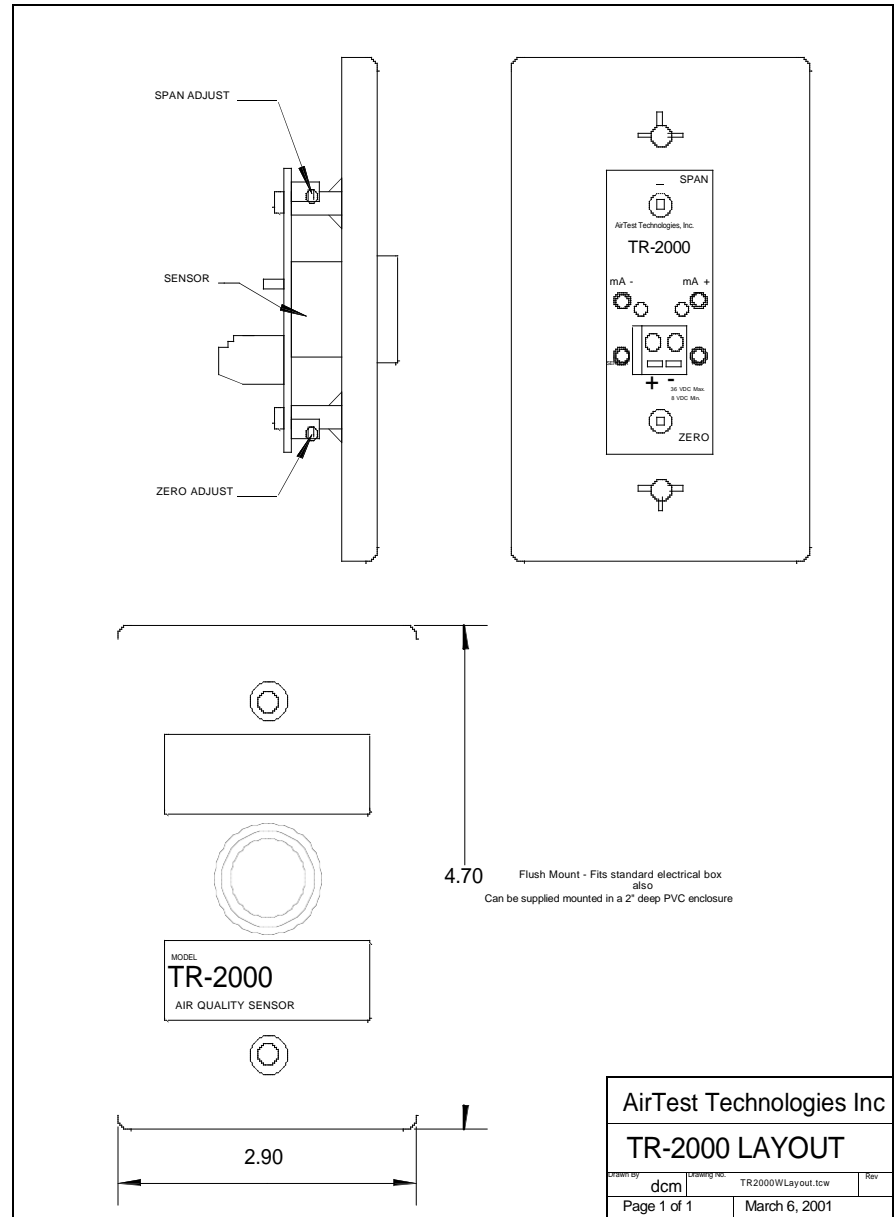
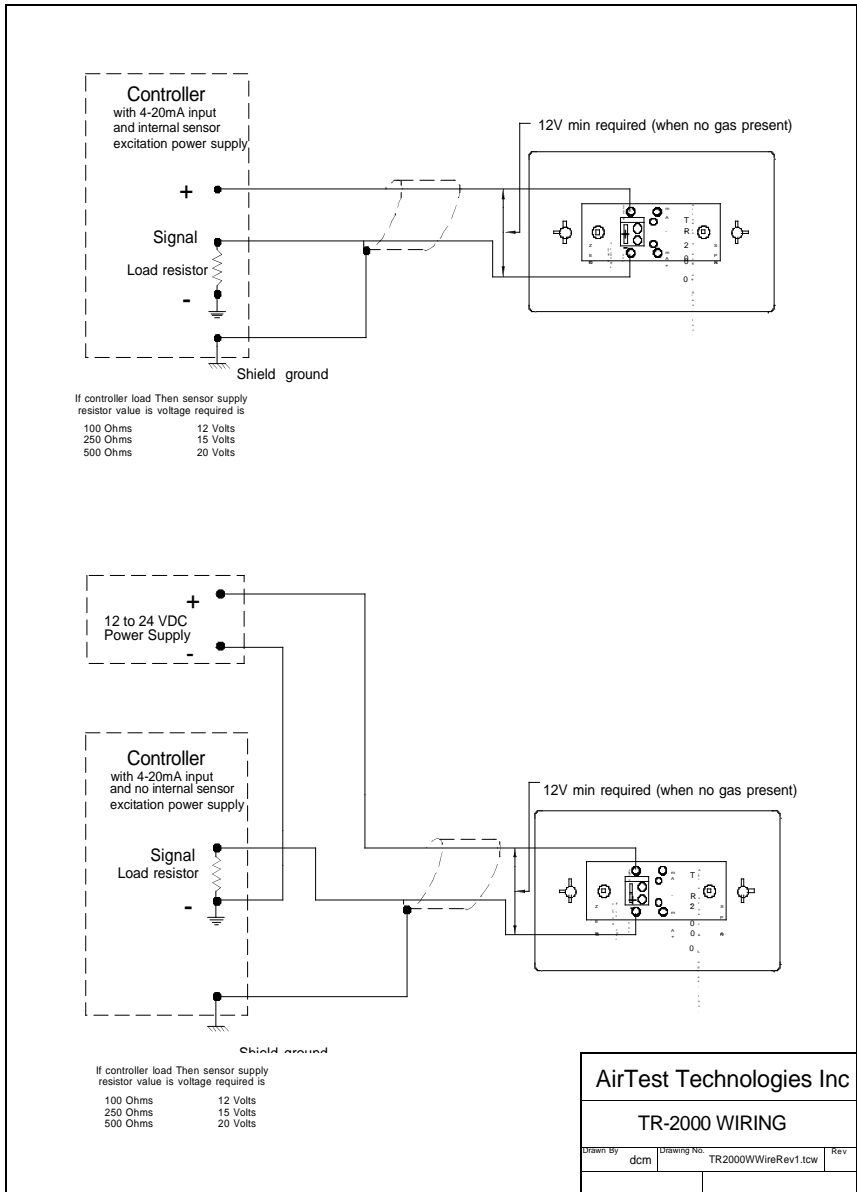

Specifications

Sensing Element	Electrochemical
Gas Sampling Method	Diffusion
Standard Range	CO 0 to 200 ppm
Sensor Life Expected	5 years
Warm-up Time	< 2 minutes
Power Requirement	12 to 30 VDC
Calibration Interval	12 months
Power Consumption	20 mA
Response Time	<1 minute
Output	4-20 mA
Operating Temperature	-20°C to +50°C -4°F to +122°F
Humidity (non-cond.)	0 to 90%
Linearity	Linear
Dimensions(LxWxD) in.	5.7 x 2.9 x 2.6
cm.	14.6 x 7.5 x 6.5
Miscellaneous Options	Flush mount
Enclosure Material	PVC
Weight	12 ounces
Approvals	Pending

AirTest continues to work on product improvement, therefore specifications are subject to change without notice

CALCULATING PPM TO SIGNAL OUTPUT AND OUTPUT TO PPM:

Formula... $OUTPUT\ SIGNAL(mA) = [GAS\ CONCENTRATION(ppm) \div FULL\ SCALE\ CONCENTRATION\ (ppm) \times 16] + 4$

For example a unit calibrated to a full scale gas concentration of 200ppm will produce an output signal of $(100 \div 200) \times 16 + 4 = 12mA$ 12mA at 100ppm CO. For 35ppm..... $(35 \div 200) \times 16 + 4 = 6.8mA$.

To determine the gas concentration level a sensor is detecting by it's output use the following formula.

$[OUTPUT\ SIGNAL(mA) - 4] \div 16 \times FULL\ SCALE\ CONCENTRATION$

For example a unit is reading 10.5mA and is calibrated to 200ppm full scale, the gas concentration detected would be 81ppm or $[10.5 - 4] \div 16 \times 200 = 81ppm$.

NOTE Most simple calculators need the equals (=) sign pressed between each operation for an accurate calculation.



ph: 206 403 1989 toll free: 1 888 385 2110 fax: 206 282 4888
E-mail: info@hvacep.com web: www.hvacep.com